

# SHOWER HEAD

FARNE C10.FA02

**CRANACH**<sup>®</sup>

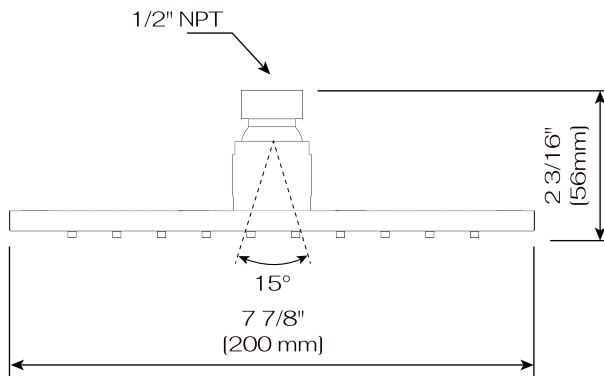
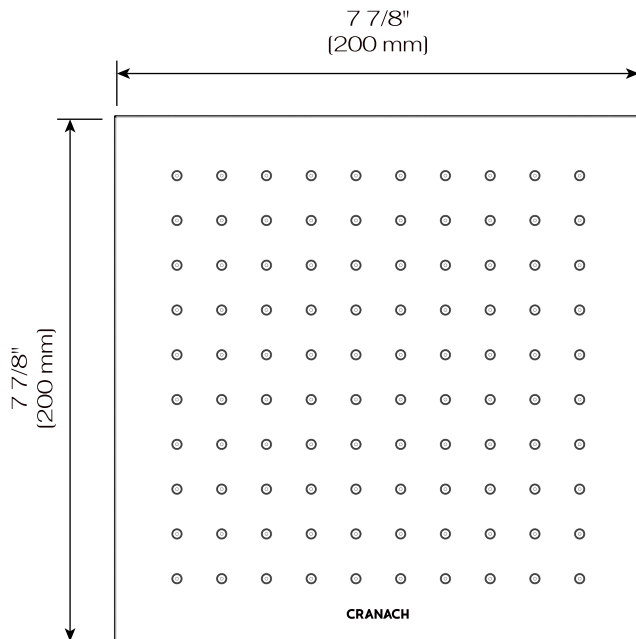

## FEATURES

- Rain Spray  
Wide and even water flow, relaxing and spa-like sensation.
- Brass Ball Joint  
Durable adjustable joint, easy positioning of the showerhead.
- Easy Clean Spray Nozzles  
Lime and calcium buildup prevention, hassle-free maintenance.
- Solid Stainless Construction  
Premium stainless steel, durable and rust-resistant.

## SPECIFICATION

- Rotation angle  $\pm 15^\circ$
- 1/2" NPT female connection
- Finish Availability: Polished Chrome/Matte Black/Brushed Nickel/Brushed Gold
- Size:  $\varnothing$  7 7/8" (200mm)
- Shower arm and flange not included

## FLOW

- 1.75 GPM @ 80 PSI MAX

## WARRANTY

- Parts and Finish: Limited lifetime warranty for residential, or 10 years for commercial purchasers and multi-family (apartments and condominiums) residential, in each case from the date of purchase.

## STANDARDS

- ASME A112.18.1/CSA B125.1

*Cranach deserves the right to make changes in specifications and materials and to change or discontinue models both without notice or obligation. Dimensions are only for reference only.*